

THIS DRAWING IS UNPUBLISHED.

RELEASED FOR PUBLICATION

ALL INTERNATIONAL RIGHTS RESERVED.

© COPYRIGHT BY TYCO ELECTRONICS CORPORATION.

LOC AF DIST 50

REVISIONS

P	LTR	DESCRIPTION	DATE	DWN	APVD
	AF	REV PER ECR 08-009983	21JUL08	JR	PD

1 - CONTINUOUS STRIP ON REELS.

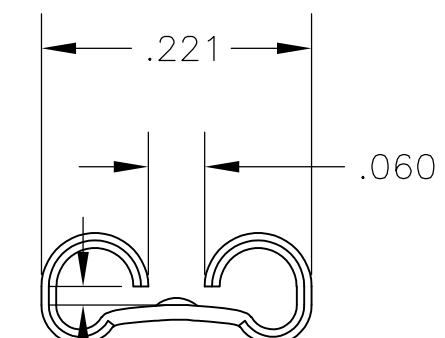
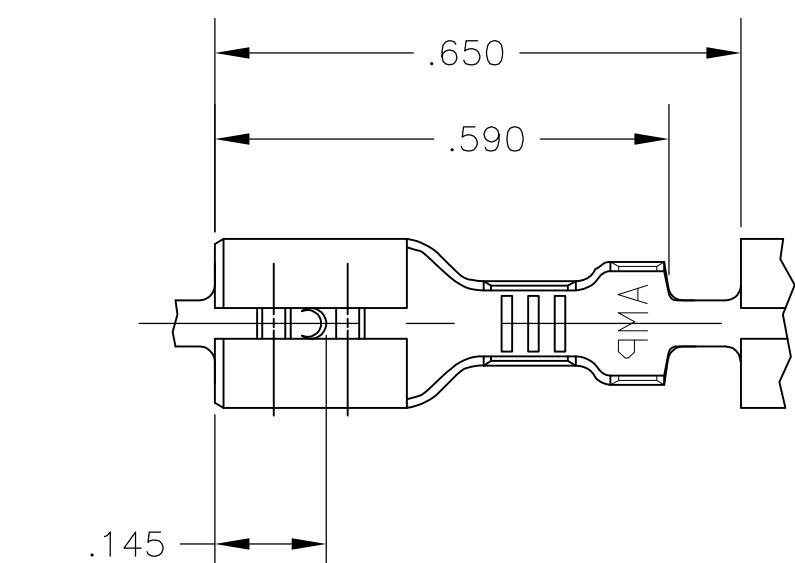

FITS .187 SERIES FASTON TAB

VIEW A-A

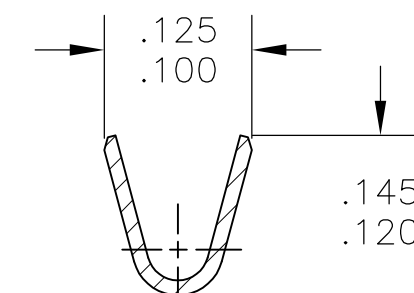

SECTION B-B

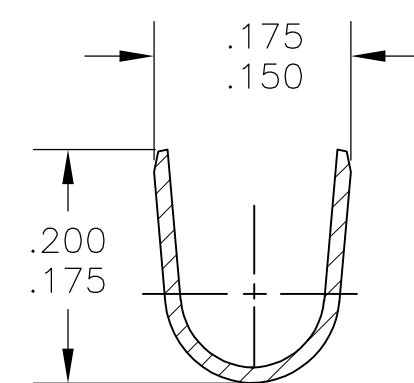

SECTION C-C

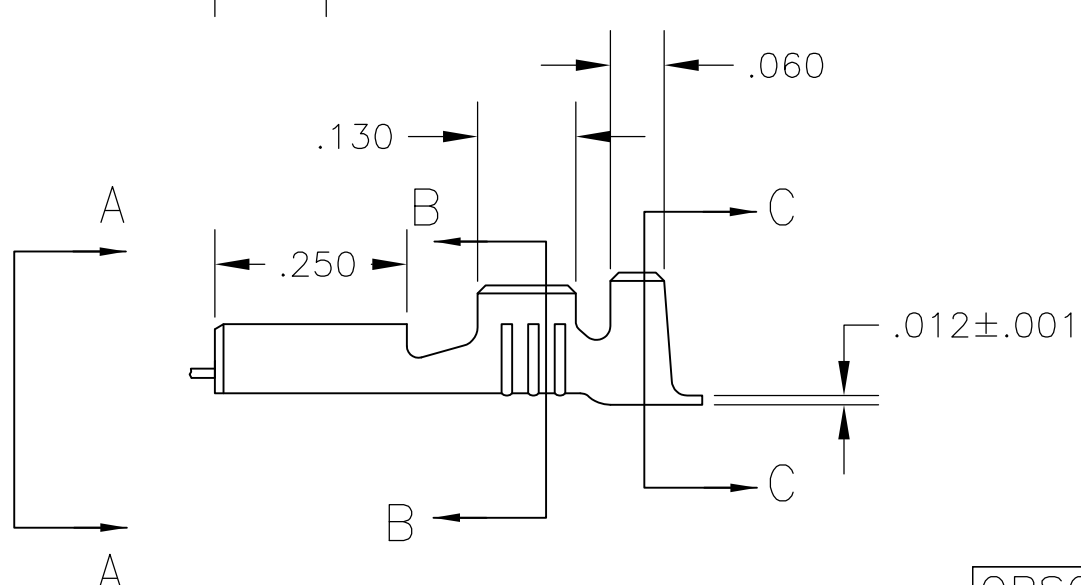

	TIN	#4H PH BRZ	.090-.130	20-16	.020 ±.001	42452-5
OBSOLETE	SILVER	#4H PH BRZ	.090-.130	20-16	.020 ±.001	42452-4
OBSOLETE	SILVER	#4H BRASS	.090-.130	20-16	.020 ±.001	42452-3
	TIN	#4H BRASS	.090-.130	20-16	.020 ±.001	42452-2
	--	#4H BRASS	.090-.130	20-16	.020 ±.001	42452-1
	FINISH	MATERIAL	INSULATION RANGE	WIRE SIZE	MATING TAB THK.	PART NO.

THIS DRAWING IS A CONTROLLED DOCUMENT.		DWN JR RUTH 10/3/86	Tyco Electronics Corporation Harrisburg, PA 17105-3608			
DIMENSIONS: INCHES		CHK G YETTER 10/3/86				
TOLERANCES UNLESS OTHERWISE SPECIFIED:		APVD R KUZO 10/8/86	NAME RECEPTACLE, FASTON, .187 SERIES			
0 PLC ± - 1 PLC ± - 2 PLC ± - 3 PLC ± .015 4 PLC ± - ANGLES ± -		PRODUCT SPEC -	RESTRICTED TO -			
MATERIAL SEE ABOVE		APPLICATION SPEC -	SIZE A3	CAGE CODE 00779	DRAWING NO C-42452	
FINISH SEE ABOVE		WEIGHT -	CUSTOMER DRAWING		SCALE NTS	SHEET 1 OF 1
					REV AF	